

Quote A is not an Atom

In Lisp, 'A is not an atom.

It is a shorthand for

(quote A)

Hence, ''A is shorthand for

(quote (quote A))

The above are merely lists.

The Lisp compiler (evaluator, eval()) *imparts certain meanings* to lists. The evaluator fetches values from symbols, but stops doing so when it hits *quote*.

Diagrams

Quote

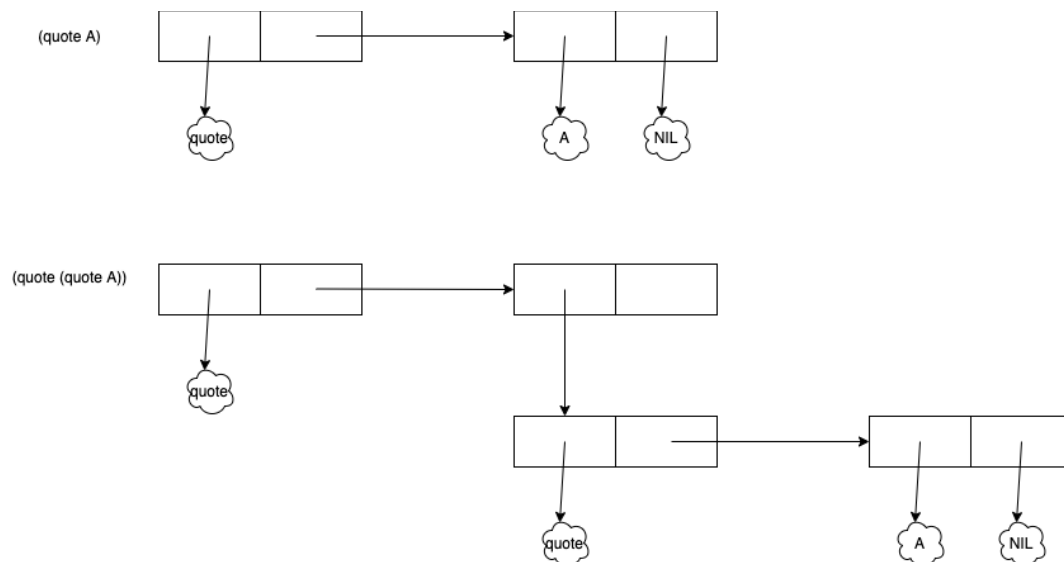

[The cloud icons represent *symbols*. Symbols are lists, too, but what is in those lists is implementation dependent. I will skip those details for now.]

Functions

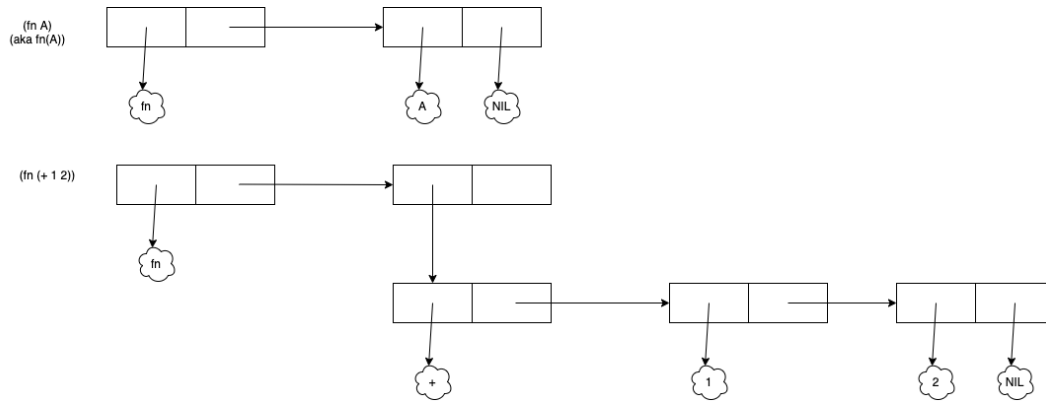

Evaling Functions

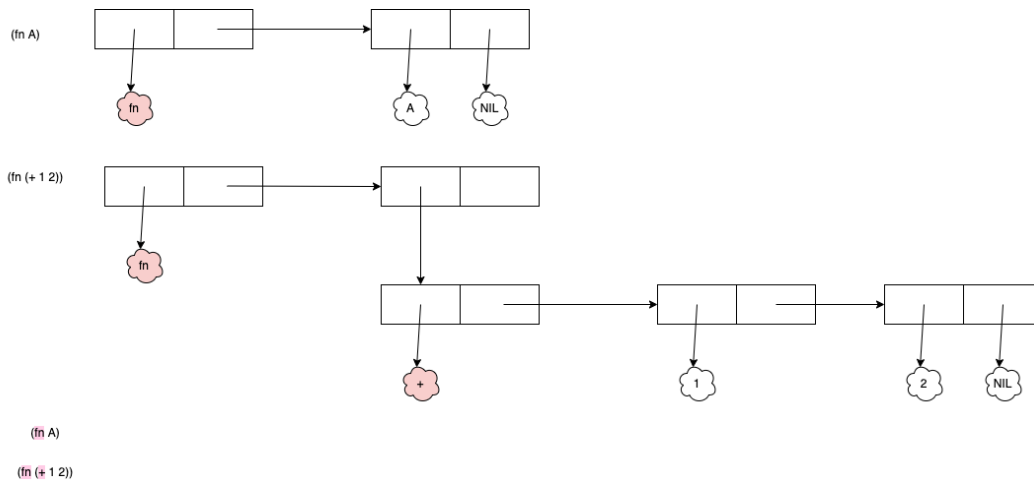

In Lisp,

`fn(A)`

is written as

```
(fn A)
```

and

```
fn(1+2)
```

is written as

```
(fn (+ 1 2))
```

In Lisp, when a list is *evaluated*, the first item is considered to be

- a function
- a macro
- something special (a builtin), like *lambda*, *quote*, etc.

I have highlighted, in red, the first items in the above lists.

The Printer

In Lisp, the *printer* function tries to print lists in a more readable form, for example

- `(a b c)` is printed as `(a b c)`
- `(quote a)` is printed as `'a`